

Smart Buffer

Ref. AA38

EFFICIENCY

Budget price*:

10 – 15 K€

Payback estimation:

<2 years

Data:

- 1 reel 250€
- 1 bottle 0,01€
- 20 reels/year saved
- +500 K bottles labelled/year

Installation time*:

Installation: 1 day

Commissioning: 2 days

Machine downtime:

1 Day

*These data are approximate and not definitive, depending on your machine configuration.

Machine application:

Evodeco, SSC

BENEFITS

- Effective and rationalized film buffering capability securing the possibility to handle speed variation
- Desynchronization of the front and back side of the station avoiding to stress this sensitive phases
- Up to +0.2%* Line efficiency
- Up to +20* reels/ year saved

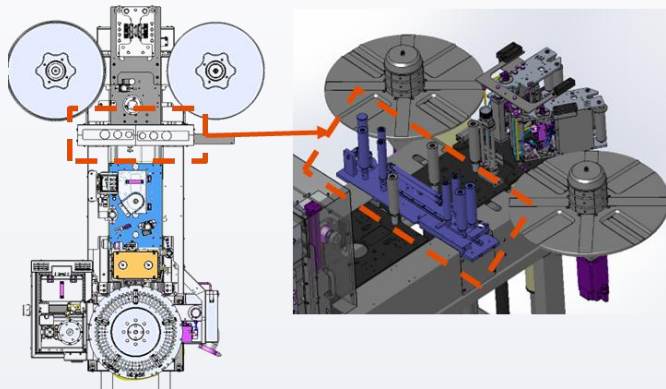

* Considering 250 M bottles/year and average speed 36 kbph

DESCRIPTION

- A new compensation element is supplied to increase the buffering capability, this grant the possibility to better handle labelling speed variations
- Desynchronization of the front and back side of the station avoiding bottle gap and related label scrape

