



# BOTTLE GUIDES

THE ADJUSTABLE GUIDES SYSTEM TO PERFORM DIFFERENT FORMATS AND TO SAVE TIME DURING CHANGE OVER OPERATIONS.

## Applicability

Available on our models INCAMATIC.

See serial numbers below in green for applicable models

IAA	IAB	IAD	IAE	IAF	IBB	IBC	IBF	IBG	IBH	IBI	IBL	IBP	IBR	IBS	IBT	IBU	ICP	IDB
IDC	IDD	IDH	IDL	IDP	IDR	IDS	IDU	IDV	IEC	IES	IEU	IEV	IFC	IFS	IFU	IGC	IGU	IFU

Subject to detailed feasibility study for your own equipment  
Contact your Service Account Manager for additional info

## Your advantages

### Safety and Ergonomics

- No heavy loads to lift for the operators.

### Flexibility

- Easier adjustment and fast change-bottle size with one operator.

### Product Quality

- Better line forming for better gripping process.

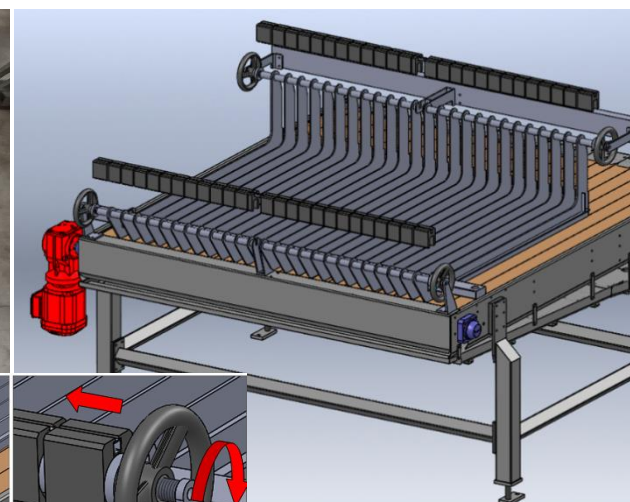

No contractual picture

## Technical description

Before guides were assembled in packs. The format change over was not quick. The guides pack was heavy and could not be removed by only one operator. The system let to process only one format and in case of more bottle formats, a different guides pack is needed.

The new configuration avoids lifting the heavy load of the guides pack. It decreases changeover time and needs only one operator presence. Reduces the total of parts to be provided for the bottle format change. The guides pack now, do not need to be removed during the changeover but just repositioned.

## Our guarantees

- Parts: 12 months
- Compliance with regulatory standards in force
- Constant support ensured
- Preserve the integrity of the machine
- Efficient After-sales service, spare parts, technical assistance
- Installation by skilled personnel

## Conversion/delivery time & misc

- Downtime (days): 1-2
- Delivery time (weeks): 6
- Need for training: N

Performance  
through  
Understanding

